



KRAKEN High Speed Top Load Case Packing System

Your answer to custom case packing needs in a small footprint



Up to 300 PPM/
25 Cases

You no longer have to be restricted by standard industry case packing system designs and larger footprints to achieve your custom solution requirements



Innovative, State-of-the art Case Packing Technology

System Feature Highlights:

- Extremely robust, fully automatic precision case packing system
- 300 PPM (25 cases) per minute
- 8' X 10' foot print
- 6 axis servo, dual gantry pick-head system
- Independent vacuum control system
- Dual product infeed
- Automatic case indexing system
- Cantilever design for quick remove change-overs
- 4" stainless steel frame and aluminum construction
- Allen Bradley controls with AB operator interface
- Single pick-head load (30 lbs)
- System available in dual or single pick-head
- System flexibility and customization to meet carton dimensioning, through-put requirements with the ability to address variable product diameters and lengths.

Multi Chub applications:

- Food (meat/vegetables/sauces dressings/cookie dough etc.)
- Chemical
- Explosives
- Caulking etc.

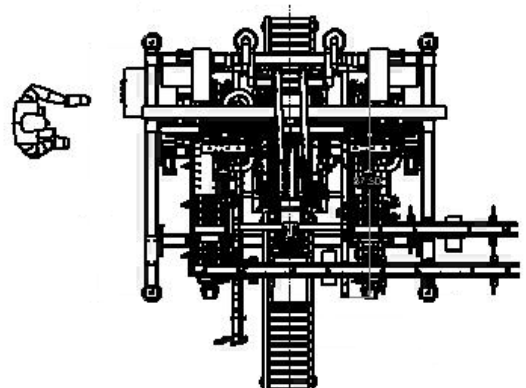

Kraken Automation Inc.

Tel: (905) 336-8089

Fax: 905-336-7205

www.krakenautomation.com